

# 10 Liter Bio Storage Vessel

Sharpsville Container's ten liter Bio Storage vessel is the latest edition to our extensive line of pharmaceutical containers. This versatile, deep-drawn container is an ideal storage vessel for pharmaceutical and bio-tech applications...

## Features at a glance:

- 316L stainless steel seamless welded construction
- 240 grit sanitary finish minimum with electro polished surface finish of 12-18 RA (other finishes available)
- ASME code stamped up to 120 degrees C
- Freezing to -70 degrees C
- 2" ferrule for standard inlet and outlet connections
- Silicone connections and filters available



Sharpsville Container is known for high quality containers in stainless steel. Our vessels, whether they are process or transport, ASME, or UN, are manufactured for the Food, Chemical, Beverage, Petro-Chemical and Pharmaceutical markets. The sizes of containers that we manufacture range from 1 gallon to 10,000 gallons. With our standard line and custom design expertise, we are capable of meeting your container requirements. Our reputation for quality and service continues to exceed our customers' expectations.



600 Main Street  
Sharpsville, PA 16150  
724-962-1100  
Facsimile: 724-962-1226  
[www.sharpsvillecontainer.com](http://www.sharpsvillecontainer.com)

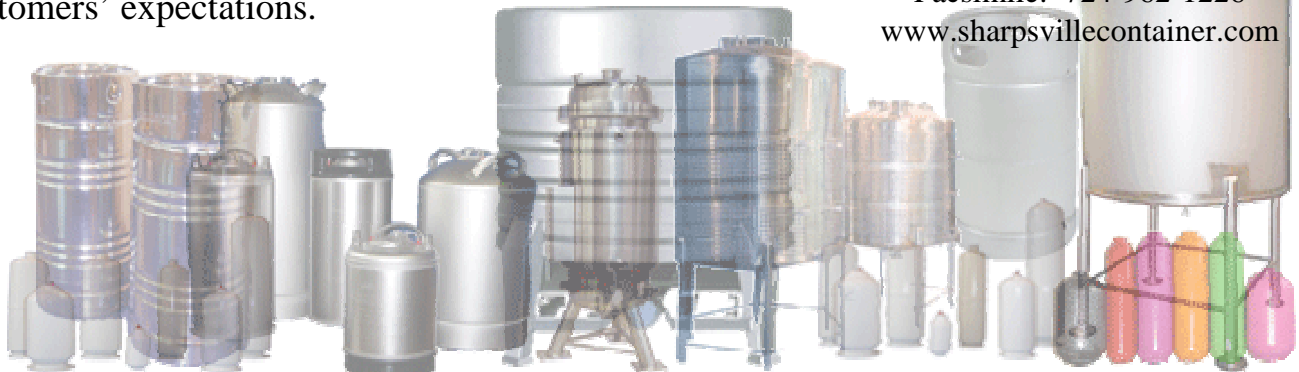

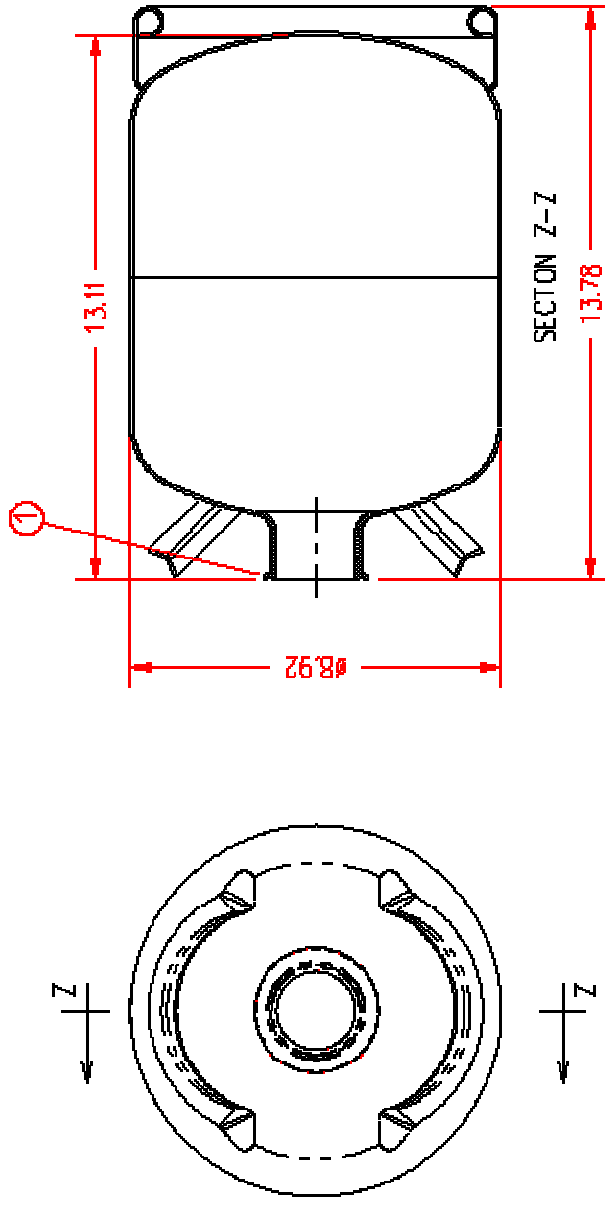

www.sharpvillecontainer.com

No.	PART NO.	DESCRIPTION	QTY.	MATERIAL
1		FERRULE, 2" DIAMETER	1	316L

GASKET MATERIAL SELECTIONS: DUNA N, EPDM, SILICONE, VITON, OR TEFLON

8.925" DIAMETER 10 LITER

FEATURES:

- 1.) 316L STAINLESS STEEL
- 2.) 12-18Rg ELECTROPOLISHED FINISH
- 3.) UN1A1 WITH 15PSI MAWP
- 4.) ASME/UN1A1 WITH 100FSI MAWP @ 250 F